

IMPORTANT: Please read and save these instructions. Read through this owner's manual carefully before using product. Protect yourself and others by observing all safety information, warnings and cautions. Failure to comply with instructions could result in personal injury and/or damage to product or property. Please retain instructions for future reference.

GASOLINE TILLER



Due to continuing improvements, actual product may differ slightly from the product described herein.

OPERATING INSTRUCTIONS



The Tiller/Cultiver tills and weeds precisely “to handle” your most difficult jobs. It handles smoothly while the “bolo-tine” tines churn soil to ten inches deep. It creates a soft smooth seed bed, even in problem stony soil.

Once you know how to use your Precision Tiller/Cultivator correctly, we guarantee you’ll love it. So first, please read this manual, It shows, step by step, how to use your Tiller /Cultivator safety.

If you have questions about any topic in this manual contact your local authorized dealer.

Table of Contents

Specifications-----	1
Safety Rules and Warnings-----	1
Assembly Instructions-----	2
Fuel Mix-----	6
Starting Instructions-----	7
Additional Information-----	8
What to do just in Case-----	9
Tilling-----	10
Cultivating-----	10
Maintenance -----	11
Storage-----	14
Troubleshooting Guide -----	15

Specifications

Tilling Scope -----	400mm
Tilling Depth-----	150mm
Engine Type-----	1E47.5F
Starting System-----	Recoil
Displacement -----	65cc
Max. Output -----	2.5kw
Engine Speed-----	10000rpm
Fuel Volume-----	1.2L
Fuel Type -----	Fresh Fuel+Quality 2 stroke oil (25:1)

Safety Rules and Warnings

You will notice throughout this owners manual safety rules and important notes. Make sure you understand and obey these warnings for your own protection.

Special safety information

<p>▲ WARNING ▲ DANGER ▲ ATTENTION: THIS SYMBOL POINTS OUR OUR IMPORTANT SAFETY INSTRUCTIONS ▲ WHEN YOU SEE THIS SYMBOL▲ HEED ITS WARNING ! STAY ALERT</p>

Safety and Warnings

▲ WARNING ▲DANGER ▲

TO REDUCE THE POTENTIAL FOR ACCIDENTS. COMPLY WITH THE SAFETY INSTRUCTIONS IN THIS MANUAL .FAILURE TO COMPLY MAY RESULT IN SERIOUS PERONAL INJURY AND OR EQUIPMENT AND PROPERTY DAMAGR.

▲WHEN YOU SEE THIS SYMBOL▲

HEED ITS WARNING ! STAY ALERT

▲ WARNING ▲DANGER ▲

IMPROPER USE OF CARE OF THIS TILLER/ CULTIVATOR, OR FAIL URE TO WEAR PROPER PROTECTION CAN RESULT IN SERIOUS INJURY.

READ AND UNDERSTAND THE RULES FOR SAFE OPERATION AND ALL INSTRUCTIONS IN THIS MANUAL . WEAR HEARING PROTECTION.

▲ WARNING ▲DANGER ▲

THE ENGINE EXHAUST FROM THIS PRODUCT CONTAINS CHEMAICALS KNOW TO THE STATE OF CALFORNIA TO CAUSE CANCER, BIRTH DEFECTS OTHER REPRODUCTIVE HARM.

Safety decal information

An important part of the safety system incorporated in this trimmer are the warning and information decals found on various parts of the trimmer. These decals must be replaced

In time due to abrasion , etc. It is your responsibility to replace the decals when they become hard to read. . The location of these decals and their part numbers for ordering are shown below.



Warnings-Do's

▲ WARNING ▲DANGER ▲
IF THE TILLER/CULTIVATOR PRECAUTIONS ARE NOT FOLLOWED , THE USER RISKS SERIOUS INJURY TO THEMSELVES AND OTHERS.
READ AND UNDERSTAND THIS MANUAL BEFORE ATTEMPTING TO OPERATE THIS

1. Always keep a firm grip on both handles while the tines are moving and / or the engine is running . BE AWARE! The tines may coast after throttle trigger is released . Make sure tines have come to a complete stop and engine is off before letting go of the Tiller / Cultivator.
2. Always maintain a firm footing and good balance. Do not overreach while operating the Tiller / cultivator. Before you start to use the Tiller / Cultivator , check the work area for obstacles that might cause you to lose your footing , balance or control of the machine .
3. Thoroughly inspect the area where equipment is to be used and remove all objects , that can be thrown by the machine.

Warning- Do's cont

1. Always keep area clear of children, pets, and bystanders.
2. Always stay alert. Watch what you are doing and use common sense. Do not operate unit when fatigued.

3. Always dress properly. Do not wear loose clothing or jewelry, they might get caught in moving parts. Use sturdy gloves. Gloves reduce the transmission of vibration to your hands. Prolonged exposure to vibration can cause numbness and other ailments.
4. While working, always wear substantial footwear and long trousers. Do not operate the equipment when barefoot or wearing open sandals.
5. Always wear ear and eye protection . Eye protection must meet ANST Z 87.1. To avoid hearing damage , we recommend hearing protecting be worn whenever using the equipment.
6. To reduce fire hazard, keep the engine, and petrol / gas storage area free of vegetative material and excessive grease.
7. Start the engine carefully , according to the manufacturer's instructions and with feet well away from tool(s).
8. Keep all nuts, bolts and screws tight to be sure the equipment is in safe working condition .
9. Use extreme caution when reversing or pulling the machine towards you..
10. Work only in day light or good artificial light.
11. Always be sure of your footing on slopes.
12. Exercise extreme caution when changing direction on slopes .
13. Always keep a safe distance between two or more people when working together .
14. **Always** inspect your unit before each use and ensure that all handles ,guards and fasteners are secure. Operating , and in place . Tiller / Cultivator with care. Follow maintenance instructions given in manual .

Warning-Don's

Don't use tiller / cultivator with one hand. Keep both hands on hands with fingers and thumbs encircling the handles . while tines are moving , and engine is running.

Don't overreach . keep a good footing at all times.

Don't run with the machine, walk

Don't work on excessively steep slopes.

Don't attempt to clear tines while they are moving. Never try to remove jammed material before switching the engine off and making sure the tines have stopped completely.

Don't allow children or incapable people to operate this tiller / cultivator.

Don't operate while under the influence of alcohol or drugs.

Don't attempt to repair this tiller / cultivator. Have repairs made by a qualified dealer or repairman .

Engine / Fuel – warning – Do's

Always use fresh gasoline ,Stale gasoline can cause damage.

Always store fuel n containers specifically designed for this purpose.

Always pull starter cord slowly until resistance is felt. Then pull cord rapidly to avoid kickback and prevent arm or hand injury. Stop the engine whenever you leave the machine.

Allow the engine to cool before storing in any enclosure/
If the fuel tank needs to be drained, this should be done outdoors.

Engine / Fuel Warning – Don'ts

Don't fuel, refuel or check fuel while smoking , or near an open flame or other ignition source, Stop engine and be sure it is cool before refueling.

Don't leave the engine running while the tiller / cultivator is unattended , stop engine before putting the tiller / cultivator down or while transporting from one place to another.

Don't refuel. Start or run this tiller / cultivator indoors or in an improperly ventilated area.

Don't run engine when electrical system causes spark outside the cylinder. During periodic checks of the spark plug. Keep plug a safe distance from cylinder to avoid burning of evaporated fuel from cylinder.

Don't check for spark with plug or plug wire removed , Use an approved tester.

Don't crank engine with spark plug removed unless spark plug wire is disconnected sparks can ignite fumes.

Don't run engine when the odor of gasoline is present or other explosive conditions exist.

Don't operate your tiller / cultivator if there is an accumulation of debris around the muffler, and cooling fins.

Don't touch hot mufflers, cylinders or cooling fins as contact may cause serious burns.

Don't change the engine governor setting or over speed the engine.

Assembly Instructions

Your tiller/cultivator comes partially assembled . You must install only the handlebars, the wheels. This will take just a few minutes if you follow the directions.

First, take all items out of the carton.

The list below , shows the parts that come with your tiller/cultivator. Check to make sure you have them.

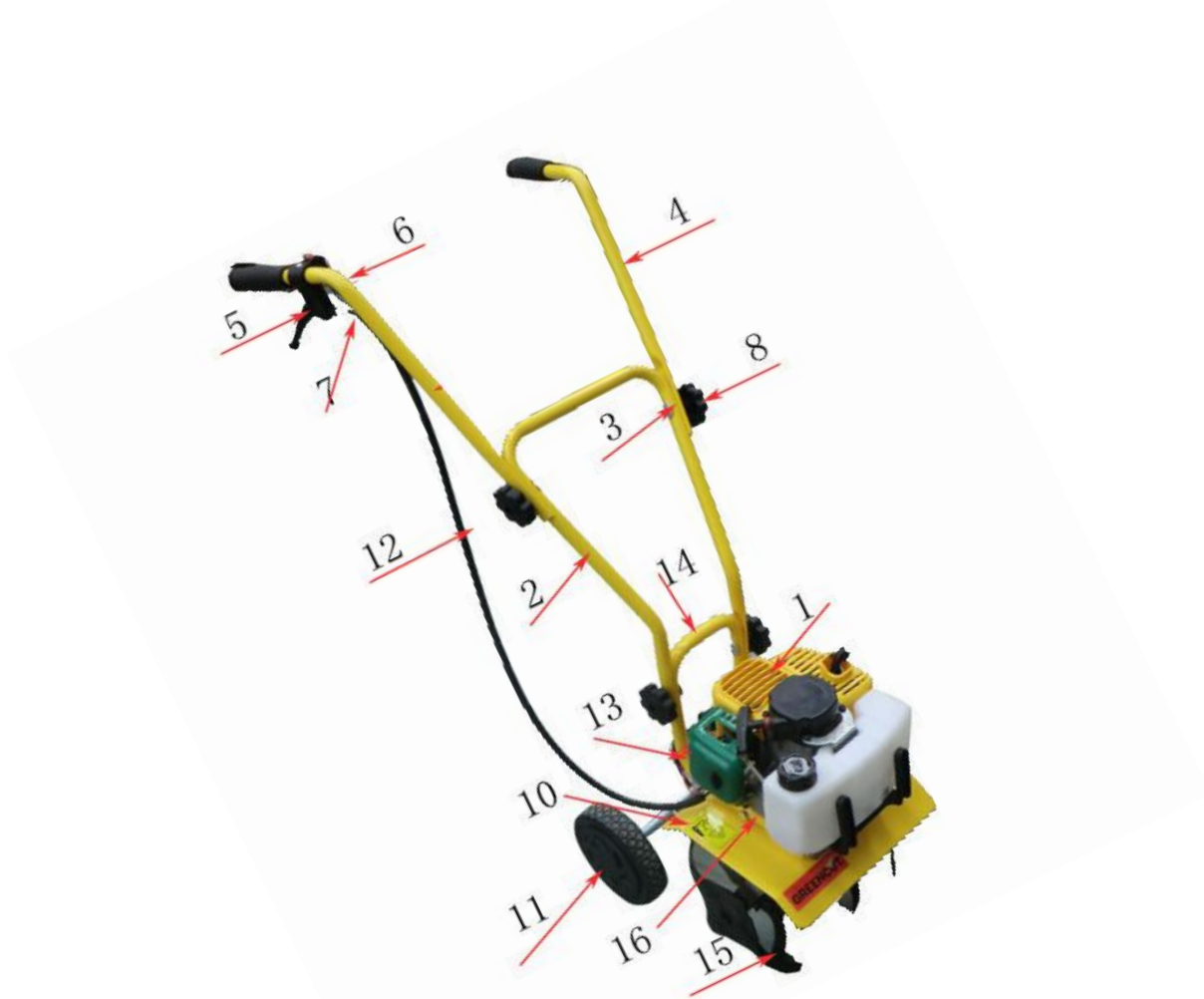

Key	Description	Qty	key	Description	Qty
1	Engine	1	9		
2	Middle handel	1	10	Safety guard	1
3	Cap screw	4	11	wheel	2
4	Left handle	1	12	Throttle lever	
5	Throttle clutch	1	13	Regulator	1
6	Throttle lever	1	14	Under handle	1
7	Right handle	1	15	Blade	4
8	Knob handle	4	16	Covervent-pipe	1

WARNING ▲DANGER ▲
 IMPROPER ASSEMBLY OF THIS TILLER /
 CULTIVATOR CAN RESULT IN SERIOUS
 INJURY
 MAKE SURE TO FOLLOW ALL INSTRUCTIONS
 CAREFULLY,IF YOU HAVE ANY QUESTIONS

2.How to Assemble Wheels.

1.Remove the look pin from the clevis pin,



2. Remove the clevis pin from the axle assy.

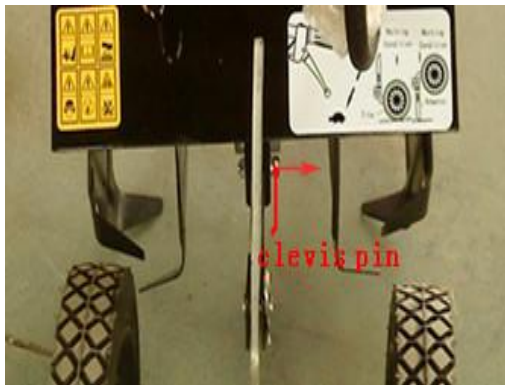

3. Remove the axle assy from the Tiller / Cultivator

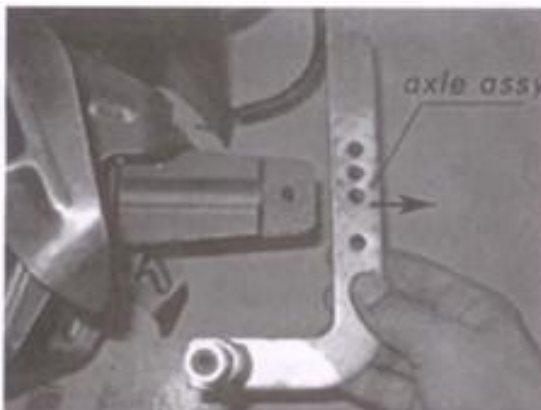

4. Place two wheel assy onto the axle assy. Please. Notice the direction of the wheel assy.



5. Fixup the wheel assy using a washer and A crew. Repeat on other side.



6. Attach the wheel cup to the wheel assy. Repeat on other side.



7. Attach the bracket assy to the Tiller. Tiller / cultivator. Reference step 3. step 2. step 1.



3. How to assemble handles

1. Attach the middle handle to the lower handle using the knobs and bolts provided. The knobs should be on the outside.



2. Attach the left handle and right handle to the middle handle using the knobs and bolts provided. The knob should be on the outside.



Fuel Mix

Your tiller/ cultivator is powered by a commercial two stroke engine which requires a fuel mixture of gasoline and lubricating oil. Use a mixture of 25 parts unleaded regular gasoline and 1 part two-stroke oil(25:1). Make sure to use gasoline with a minimum octane number of 90 ROZ.

Recommended mixing ratio

Gasoline 25: Oil 1

Exhaust emission are control led by the fundamentals engine parameters and components (eq. carburators , ignition timing and port timing)without addition of any major hardware or the introduction of an inert material during combustion.

How to mix fuel:

1. Pour 2.5 liters of the gasoline into a safe container. Do not mix the fuel and oil in the engine fuel tank.
2. Add 0.1 liters of two-stroke engine oil to the gasoline and mix. Then add the rest of the gasoline.
3. Screw the cap onto the gasoline can. Then swirl the can to blend the oil and gas.

Fueling the unit:

1. Carefully pour the fuel mix into the tiller / cultivator's fuel tank.
2. Put fuel onto the fuel tank to 80% of the full capacity.
3. Fasten the fuel cap securely and wipe up any fuel spillage around the unit.

IMPORTANT: Two stroke fuel separates and ages. Do not mix more than you will use in a month.. Using old fuel can cause difficult starting or engine damage. Shake fuel container to thoroughly mix fuel before each use. Do not attempt to run your engine on gasoline only, use proper fuel mixture.

REMEMBER

- Always mix two-cycle oil with gasoline before fueling your tiller / cultivator. Never, ever run your tiller/ cultivator on gasoline alone. This will run your engine and void all warranties.

- Always use a clean gas can and always use unleaded gas.
- Never try to mix the oil and gasoline in the engine fuel tank.
- Always mix oil and gas in the proper proportions (0.1 liters) of two-cycle engine oil to 2.5 liters of unleaded gasoline.
- Gasohol – It can cause deterioration of rubber and / or plastic parts and disruption of engine lubrication.
- Oil for 4-cycle engine use or water coded 2-cycle engine use – it can cause spark plug fouling, exhaust port blocking ,or piston ring sticking.

▲ WARNING ▲ DANGER ▲
 FUEL IS EXTREMELY FLAMMABLE.
 HANDLE IT WITH CARE KEEP AWAY FROM
 IGNITION SOURCES. DONOT SMOKE WHILE
 FUELING YOUR EQUIPMENT.

IMPORTANT NOTE:

DO NOT use old or stale oil/gasoline mixture Always use the proper oil/gasoline mixture, If you do not, your engine will suffer rapid, permanent damage. And your will void the engine warranty.

Gasoline tiller	1	2	3	4	5
2-cycle Oil ml	33.3	66.7	100	133.3	166.7

Starting Instruction

Starting Your Tiller / Cultivator for the first time

1. Fill the fuel tank with the proper oil/gasoline mixture.(see previous section)
2. Hand tighten the gasoline cap just until it’s snug.
3. Move run/stop lever into the “run” position



4. slide the choke lever back to close the engine choke.



5. Locate the purge bulb on the upper right of the engine, in the front of the fuel tank. It sends fuel into the carburetor, for easy starting

Press the purge bulb until you see fuel flow through the clear fuel return line. Since you're starting "cold", you may need to press six to eight times. As soon as fuel starts flowing through the clear fuel line, stop pressing !



6. Don't pull the throttle trigger during the starting of the engine.

7. Pull the starter cord slowly until resistance is felt. Then give the recoil starter cord a few short, brisk pulls until the engine fires. During cold starting. You may need to pull at least three or four times before the engine fires.

Note: When the choke is closed, never pull the cord more than four or five times. Overpull may cause flooding. Also, bear in mind that, when the engine fires, it only coughs or sputters, and will not run on choke.

8. Move the choke lever to the close(choke) position.



9. Then pull the starter cord again. The engine should be start and run. Let the engine warm up two to three minutes before using.

Follow these steps whenever you are starting the engine “cold”, or when the engine has run dry and you have just add fuel.

Remember, always use short , brisk pulls.

Don't give the cord a long , forcefull yank, And, do not let the cord snap back into the starter housing.

Starting a warm engine.

1. Slide ignition switch to START position.
2. Move the choke lever to the Open (run)position.
3. If there is no fuel in the clear return line, push primer bulb 3-4 times or until fuel is visible in the line.
4. Pull starter rope using short pulls , 1/2 to 2/3 of the rope length
5. Pull starter rope using short pulls, use “First Time” starting procedure
6. With engine running , and both hands on the handles, squeeze throttle trigger gradually to increase the engine speed and engage the tines.

Additional Information

How to stop the engine

Simply push the start / stop switch to “ stop.”

This will stop the engine instantly. If it should ever fail to do so. Just pull out the choke button.

The engine will stop at once



About the choke

The choke controls the amount of air draw into the engine. Your tiller / cultivator will run only if the choke is open –that is , if the choke is pushed in.

A Special Feature (with the idle set properly and the engine running.)

Even when the engine is running , the tines won't turn unless you press the throttle lever on the handlebars . And, when you release the throttle lever . the tines will stop

A Tip for extending your engine's life.

After you start the engine , let your tiller / cultivator warm up for two to three minutes before you use it. Then, before you put your tiller / cultivator away , Let it idle for a minute to give the engine a chance to cool down.

WARNING ▲DANGER ▲

IF ENGINE DOES NOT STOP WHEN SWITCH IS PUT IN THE STOP POSITION. RELEASE THE THROTTLE ALLOW ENGINE TO IDLE.

PUT THE TILLER / CULTIVATOR DOWN . AND PULL THE CHOKE BUTTON OUT TO COLD START (CLOSED) POSITION.

CHECK AND RETURN IGNITION SWITCH TO ON POSITION BEFORE STARING ENGINE AGAIN.

What to do just in case

If you follow the normal starting procedure. You should have no problem starting your tiller / cultivator . But , just in case you do have problem , here is what to do.

Make sure the run / stop switch is on “run” push the switch into the “run” position. If the switch was on “stop “ when you pulled the cord , you may have flooded the engine.

- First , examine the spark plug . Use a 19 mm spark wrench.
- Remove the cap over the spark plug.

IMPORTANT NOTE:

To avoid possible damage to the threads , do not try to remove the plug from a hot aluminum cylinder head.

- Unscrew the spark plug.

Starting a flooded engine

1. If the end of the spark plug is wet, the engine may be flooded . **Make sure the switch is in the stop position , disconnect spark plug wire and remove plug. Use a paper towel or a clean rag to dry the spark plug, then , with the spark**

Plug out of the engine , pull the starter cord several times. Shake the fuel out of the inside of the plug and air dry . Next , replace the spark plug , Use the wrench to tighten it and replace the cap. Next , put the switch in the start position and pull the choke button out . Pull the starter cord three or four times until the engine coughs or Sputters. Open the choke (push the choke button in) and pull the cord a few times. The engine should start and run.

2. If the end of the spark plug is dry , check to see if the fuel line is blocked. The fuel line runs from the fuel tank to the carburetor , Pull it off at the carburetor end , Fuel should drip slowly from the line. Wipe off any excess or spilled fuel.

If fuel does not drip from the line, check the line for any bends or pinches . Kinks in the line restrict the flow of the fuel to the engine . just straighten out the line. Reconnect. Then follow the normal starting procedure . If fuel drips too freely , the line may be disconnected from the fuel filter. You will find the fuel filter inside the fuel tank. Just re-attach the line to the filter , and put the filter back in the tank. Then follow the normal starting procedure.

▲ WARNING ▲ DANGER ▲

MAKE SURE THE START / SPORT SWITCH IS IN THE STOP POSITION.

KEEP PLUG WIRE AWAY FROM ENGINE TO AVOID UNINTENTIONAL SPARK.

What to do just in case out.

Here is Another way to start your tiller / cultivator

If you follow the steps above and your engine still won't start, try this:

1. Push the switch to "start"
2. Move the choke lever to open the choke .
3. Press the plastic bubble a few times .
4. Give the starter cord a few short , quick pulls . The engine should start and run.
5. If the engine does not start, then move the choke lever to close the choke. Pull the starter cord four to give times . The engine should sputter or cough.
6. After the engine sputters , push the choke button in , Then pull the starter cord.The engine should start and run
7. If the engine still does not start, repeat Step 2 through 6 .

IMPORTANT NOTE:

Never use starting fluids. Starting fluids will cause permanent engine damage. Using them will void the warranty.

IMPORTANT NOTE:

Before you use your tiller / cultivator. Read the safety rules & warnings on pages 3-6.

Tilling

Now you are ready to use your Tiller /cultivator .

If you have seen other tiller / cultivators , your tiller / cultivator may surprise you , It tills best when you pull it backward! You see, when you pull your tiller / cultivator backward , you give extra resistance to the tines, so they dig deeper .What is more when you go backward , you erase your footprints, so your soil stays light and fluffy , with other Tiller / cultivator , by contrast , you walk right over the soil you have just cultivated , packing it down , so it is less plantable . Place your tiller / cultivator at the head of the row or area you want to cultivate .Start it up. Then use an easy rocking motion .First , pull your tiller /cultivator backward. Then let it move forward just a little bit , Then pull it back again. This will help you cultivate deeper. Keep repeating these steps until you've tilled and entire row. Start again on the next row. It's much like running a vacuum cleaner!

You can even control depth

For deeper cultivatoing:

Move your tiller / cultivator slowly back and forth , as you would a vacuum cleaner . Work the same area over and over until you've dug to your desired depth.

For shallow cultivating:

Switch the tines to the cultivating position . Then move your tiller / cultivator quickly over your soil surface.

For big weeds or tough toots:

Remember , any tiller / cultivator will tangle in tall grass, stringy vines , or super-big weeds. So, if you have a “backyard jungle,” first use a knife , pruner , or brush cutter to chop up the overgrowth . If the tines become tangled Let your tiller / cultivator rock back and forth over the tough spot, until the tines slice through the weed or root.

▲ WARNING ▲DANGER ▲
THE OPERATOR OF THIS TILER
/CULTIVATOR IS RESPONSIBLE FOR
ACCIDENTS OR HAZARDS OCCURRING
TO HIMSELF,OTHER PEOPLE, OR THEIR
PROPERTY.

Cultivating

Now you're ready to cultivate or weed.

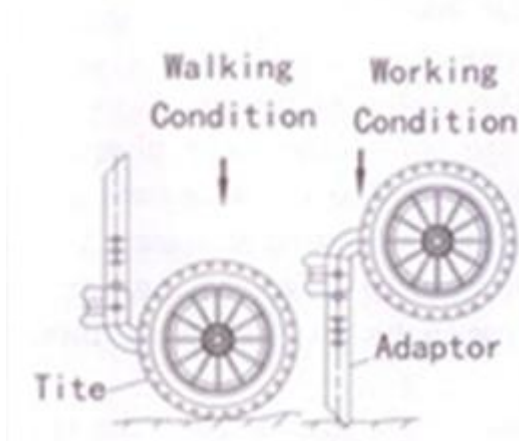
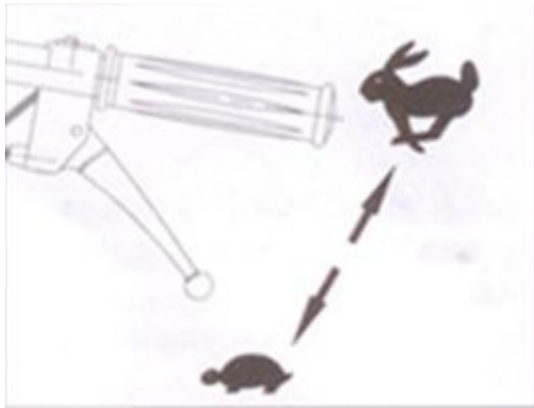

Guide your tiller /cultivator where you want to weed and start it up. Pull your tiller /cultivator backward slowly. Then let it move forward a bit, in a gentle rocking motion . watch it slice, shred , and bury those weeds ! Got tough weeds ? Lighten your pressure on the throttle to slow your tiller/ cultivator down.

Then work back and forth until your tiller /cultivator chops up the weeds . It's easy and anyway , turn the engine off completely before trying to clear them.

▲ WARNING ▲ DANGER ▲
IF YOUR TINES GET JAMMED OR ENTANGLED,
SHUT OFF THE ENGINE AT ONCE .
REMOVE THE OBSTRUCTION WHILE THE
ENGINE IS OFF NEVER TRY TO REMOVE AN
OBSTRUCTION WHILE THE ENGINE IS
RUNNING. SERIOUS INJURY CAN RESULT

Maintenance

How to check , Clean and change the air Filter check the air filter every 25 hours of use or more frequently if used under dusty conditions. A clogged air filter may increase fuel consumption while cutting down the engine filter or with a deformed filter element because unfiltered dusty air will quickly ruin the engine .

Cleaning air filter

1. Remove the air cleaner cover by pulling the tab on side and take out the 3 filter element.
2. Using neutral detergent and warm water to clean the filter elements . After cleaning , air dry the element completely and moisten with a small amount of motor oil.
3. Please the filter element into the air cleaner housing and press the cover against the housing until it clicks.

Idle Speed Adjustment

1. Warm up engine before adjust idle speed.
2. The idle speed adjustment screw controls the throttle opening at idle position.
3. When the engine tends to stop frequently at idling mode. Turn the adjusting screw clock wise.
4. If the tines continues to rotate after releasing the trigger , turn the adjusting screw counter-clockwise.

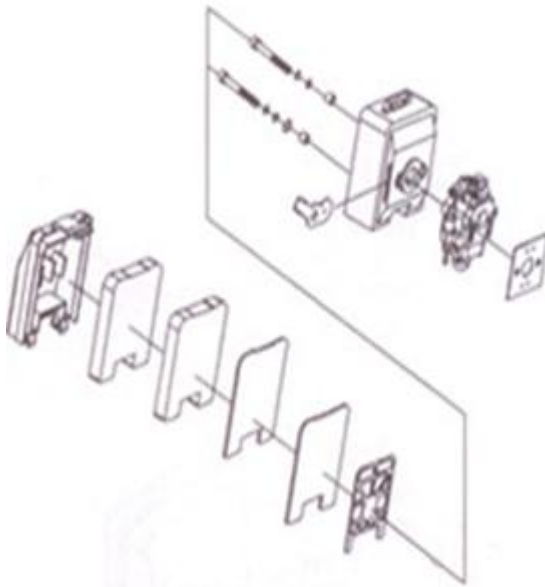

Clear Blockages From the fuel line & filter

After you've used your tiller /cultivator for a few seasons, check for blockages in the fuel tank and fuel filter. Such blockages can keep your tiller / cultivator from starting.

Clear any blockages you see in the tank, fuel filter , or fuel line .

Remember: The fuel filter is located inside the tank . Then use normal starting procedure to start your tiller / cultivato

Spark Plug:

1. Starting failure and mis-firing are often caused by a fouled spark plug.Clean the spark plug and check the that the plug gap is in the correct range .(0.6 ~0.7mm)
2. CAUTION :Do not over tighten the spark plug. To install the spark plug first turn the plug until it is finger tight, then tighten it a quarter turn more with a socket wrench.

Maintenance cont .

Muffler

- Inspect periodically , the mffler for loose fasteners, any damage or corrosion .If any sign of exhaust leakage is found , stop using the machine and have it .repaired immediately.
 - Note that failing to do so may result in the engine catching on fire .
- 3.Check to see if any oil or grease has worked its way in between the clutch lining and drum, and if wipe it away using oil-free, lead- free gasoline.

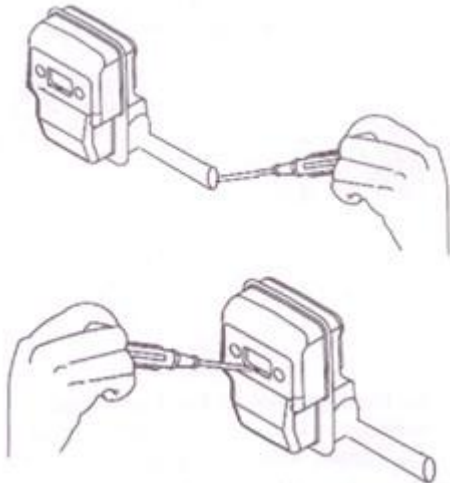

Intake Air cooling vent

- Never touch the cylinder , muffler , or spark plugs with your bare hands immediately after stopping the engine . The engine can become very hot when in operation , and doing so could result in severe burns.
- When checking the machine to make sure that it is okay before using it , check the area around the muffler and remove any devris . Failing to do so could cause the muffler to become overheated , and that this in turn could cause the engine to catch to fire . Always make that the muffler is clean and free of debris before use.
- Check the intake are cooling fins after every 25 hours of use fo blockage . Note that it is necessary to remove the engine cover in order to view the upper part of the cylinder.

Procedures to be performed after every 100 hours of use

1. Remove the muffler , insert a screwdriver into the vent , and wipe away any carbon buildup. Wipe away any carbon buildup on the muffler exhaust vent and cylinder exhaust port at the

same time .

2. Tighten all screws, bolts , and fittings ,.
3. Cheek to see if any oil or grease has workded its way.

in between the clutch lining and drum,and if it has,wipe it away using oil-free,lead-free gasoline.

Maintenance cont . (ENGINE)

System / component	procedure	Before use	Every 25 hours	Every 50 hours	Every 100 hours	Note
Fuel leaks, Fuel spillage	Wipe out	✓				
Fuel tank, air filter, Fuel filter	Inspect, clean	✓	✓			Replace if necessary
Idle adjusting screw	See adjusting Idling speed (pg.9)	✓				Replace carburetor If necessary
Spark plug	Clean and read Just plug gap			✓		GAP: ".025" (0.6-0.7mm) Replace if necessary
Cylinder fins, intake Air cooling vent	Clean		✓			
Muffler ,spark arrester , Cylinder exhaust port	Clean			✓		

IMPORTANT : Time intervals shown are maximum . Actual use and your experience will determine the frequency of required maintenance.

Storage

Each fall – or before you store your tiller / cultivator for any long period – be sure to take these measures :

1. Do not store your tiller / cultivator with fuel still in it . Even under ideal conditions , stored fuel containing ethanol or MTBE can start to go stale in 30 days .And , since stale fuel has a high gum content , it can clog the carburetor. This , in turn ,will restrict fuel flow. So when you're ready to store your tiller / cultivator , or will not be using it for more than 2 weeks , drain the fuel tank completely
2. Next , restart the engine to make sure no fuel is left in the carburetor, Then run the engine until it stops , This will prevent gum deposits , forming inside of the carburetor and possible engine damage.
3. Disconnect spark plug wire and remove the spark plug, (Use a 19 mm spark- plug wrench.). Pour about a teaspoon of clean , air- cooled , 2-cycle oil through the spark – plug hole into the combustion chamber .Slowly pull the starter cord two or three times to coat the inside of the cylinder wall.
4. Inspect the spark plug, and if necessary , clean it , If you need to replace it , buy a champion on L8RTF.
5. Install the spark plug , but leave the spark plug wire disconnected.
6. Clean the air filter as described on page 14
7. Clean dirt ,grass , and other materials from the entire machine..
8. Wipe the tines with oil or spray them with WD – 40 , to prevent rusting .
9. Oil the throttle cable and all visible moving parts . (Do not remove the engine cover.)
10. Order new parts to replace any that are badly worn or broken . Just contact your local authorized dealer . But do it early. So you'll have the parts well before the next gardening season starts.
11. Store your tiller / cultivator – in an upright position – in a clean , dry place,
12. Do you have fuel left over from last season ? Dispose of it properly . Buy fresh oil and gasoline next season

How to prepare your tiller/cultivator restarting

In the spring , when you take your tiller / cultivator out of storage , remove the spark plug .Pull the starter cord there or four times to clean oil from the combustion chamber. Wipe oil from the spark plug, Place the spark plug back into the cylinder .Reconnect the spark plug wire back on the spark plug . Then follow the steps to refuel and restart your tiller /cultivator .

Again , check the carburetor.

If your tiller /cultivator won't restart in sprin – or if it lacks its usual power the carburetor may need attention.

Check the spark plug too.

If your tiller /cultivator won't start , or if it lacks full power , the spark plug may be at fault , Check to see if the plug is fouled with oily black deposits. Clean or replace it if it is . Also, check whether the center electrode is rounded at the end. Or if the ground electrode is worn . If either is the case. You should replace it with a champion L8RTF

Spark plug . Use a 19 mm spark plug wrench to install it. Adjust the plug gap to 0.6~0.7 mm to install the spark plug first turn the plug until it is finger tight, then the tighten it a quarter turn more with a socket wrench.

IMPORTANT NOTE:

To avoid possible damage to the threads, do not try to remove the plug from a hot aluminum cylinder head.

Troubleshooting Guide

Case 1. starting failure

check	Probable cause	Action
Fuel tank	Incorrect fuel	Drain it and fill with correct fuel
Fuel filter	Fuel filter is clogged	Clean
Carburetor Adjustment screw	Out of normal range	Adjust to normal range
Sparking (no Spark)	Spark plug is fouled/wet Plug gap is incorrect	Clean / dry correct (GAP: 0.6~0.7 Mm)
Spark plug	Disconnected	Retighten

Case 2 . Engine starts but does not keep running / hard re –starting .

Check	Probable causes	Action
Fuel tank	Incorrect fuel	Drain it and fill with correct fuel
Carburetor Adjustment screw	Out of normal range	Adjust to normal range
Muffler , cylinder (exhaust port)	Carbon is built-up	Wipe away
Air cleaner	Clogged with dust	Clogged with dust
Cylinder fin, Fan cover	Clogged with dust	Clean